



Installation and configuration manual with Sol-Ark

Pytes Lithium Battery HV48100 SE

with Sol-Ark Inverter 30kW / 60kW



WARNING: HV48100 SE is a high voltage DC system and must be operated by authorized person only.

Warning

Before connecting

- 1) Please check products and components according to enclosed packing list after unpacking. Please contact PYTES if there is any damage or missing of products and / or components.
- 2) Make sure power sources are cut off and battery system is powered off before installation.
- 3) Wiring correctly by identifying positive and negative cables to ensure no short circuit with external devices.
- 4) It is forbidden to connect the battery directly with AC power.
- 5) Battery system must be well grounding and the resistance must be less than 0.1Ω ;
- 6) Make sure the electrical parameters of battery system are compatible with related equipment.;
- 7) Keep the battery away from water and fire.

In Operation

- 1) Battery must be physically powered off in case of any move or repair.
- 2) It is forbidden to connect HV48100 SE to other types of battery;
- 3) It is forbidden to connect the battery to a faulty or incompatible inverter;
- 4) It is forbidden to disassemble the battery (QC label removed or damaged);
- 5) In case of fire, only dry powder fire extinguisher can be used, liquid fire extinguishers are prohibited ;
- 6) Please do not open, repair or disassemble the battery other than staffs from Pytes or authorized by Pytes. Pytes do not undertake any consequences or related responsibility caused by violation of safety operation or design, production and equipment safety standards;

Caution

- 1) Please read this manual carefully before installation and any operation.
- 2) Charge the battery every 6 months to keep battery SOC > 90% if long term storage.
- 3) Battery must be charged within 12 hours when low voltage alarm triggered.
- 4) Battery DC output voltage exceeds 48V. It is vital to pay attention to personal safety in any case when operating.
- 5) All battery terminals must be disconnected before maintenance.
- 6) Please contact with Pytes within 24 hours if there is anything abnormal.
- 7) Battery being damaged directly or indirectly by above cases will result in warranty failure.

Note :This part only includes the battery and inverter connection.

Please refer to other documents for the battery installation.



CONTENTS

BOM LIST [6](#)

1. Communication Cable Connection 8

2. Power Cable Connection_ 9

[Step.1](#) 9

[Step.2](#) 10

[3.](#) Set The DIP Switch [11](#)

4. Start up the system [12](#)

 Step.1 [12](#)

 Step.2 [13](#)

 Step.3 [14](#)

 Step.4 [15](#)

5.Change the battery setting of the inverter..... [15](#)

 Step1. [15](#)

 Step2. [16](#)

6.Check the battery soc [17](#)









 Step.1 [17](#)

 Step.2 [17](#)

7.System monitoring [18](#)

Prepare tools for installation

Wear the safety gears listed in the installation manual at all time.

		
Wire Cutter	Crimping Modular Plier	Cable Ties
		
Screw Driver Set	Electric Screw Driver	Insulating Gloves
		
Adjustable Wrench	1500VDC Isolating nut drivers	2000VDC Multimeter

It is recommended to wear the following safety gears when dealing with the system.



绝缘手套



安全护目镜



安全鞋

BOM LIST

Before installation, you should prepare following items.

Item	Remarks	Quantity
Power Cable (DC)	<input type="checkbox"/> Cable diameters: 4awg(≥ 25 mm) <input type="checkbox"/> Only copper cables may be used. <input type="checkbox"/> The DC cables must be sized for the maximum battery voltage and the maximum battery current (see battery manufacturer documentation).	1pair
Earthing cable		1
Com. Cable	CAN communication or RS485 communication	1
Battery	HV48100 SE series	Depends on the number of Battery module
Inverter	Sol-Ark 30kW or Sol-Ark 60kW	1

Definition of RJ45 Port Pin for BMS is as follow.

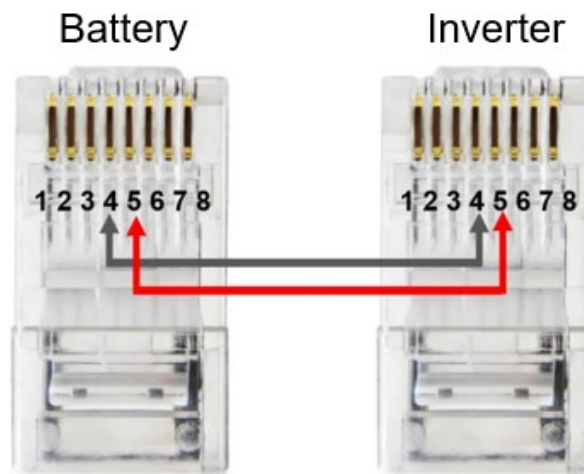

CAN port definition

HOW TO INSATLL

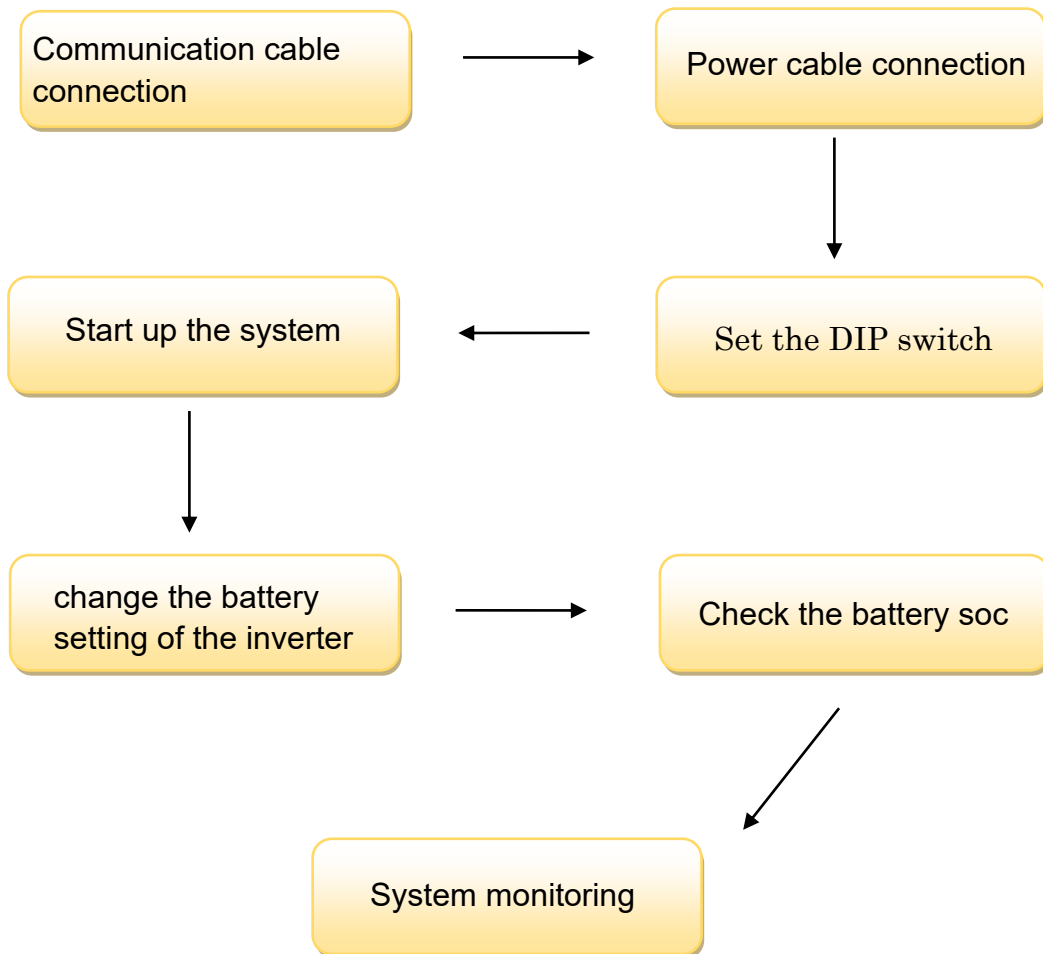

CAUTION: If you want to get more inverter-related settings, please refer to the inverter user manual first.

1. Communication Cable Connection

Connect the end of the cable to the inverter communication port as shown in pic 1.1.1. Make sure use **BMS1** port.

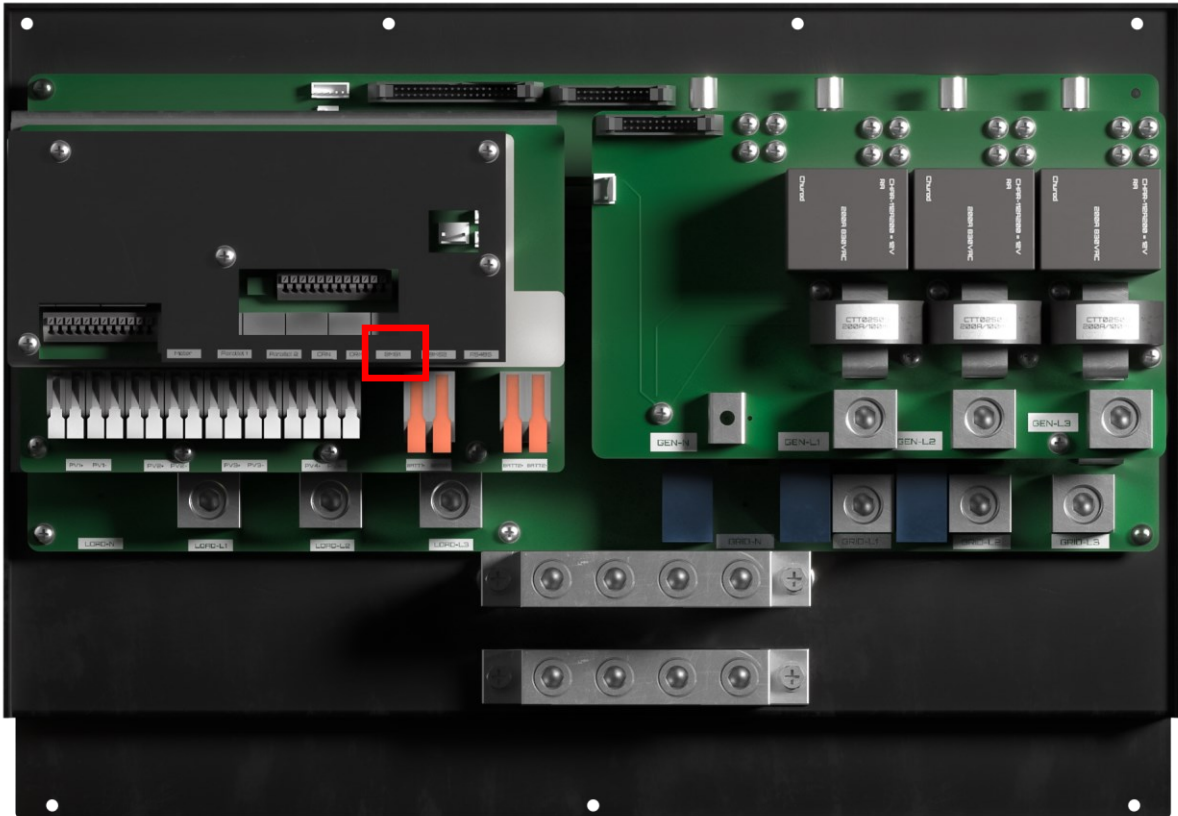

Connect the other end of the cable to the COM 1 port on the side of the HV48100 SE cabinet as shown in pic 1.1.2. (Ensure the correct sequence of communication cable)

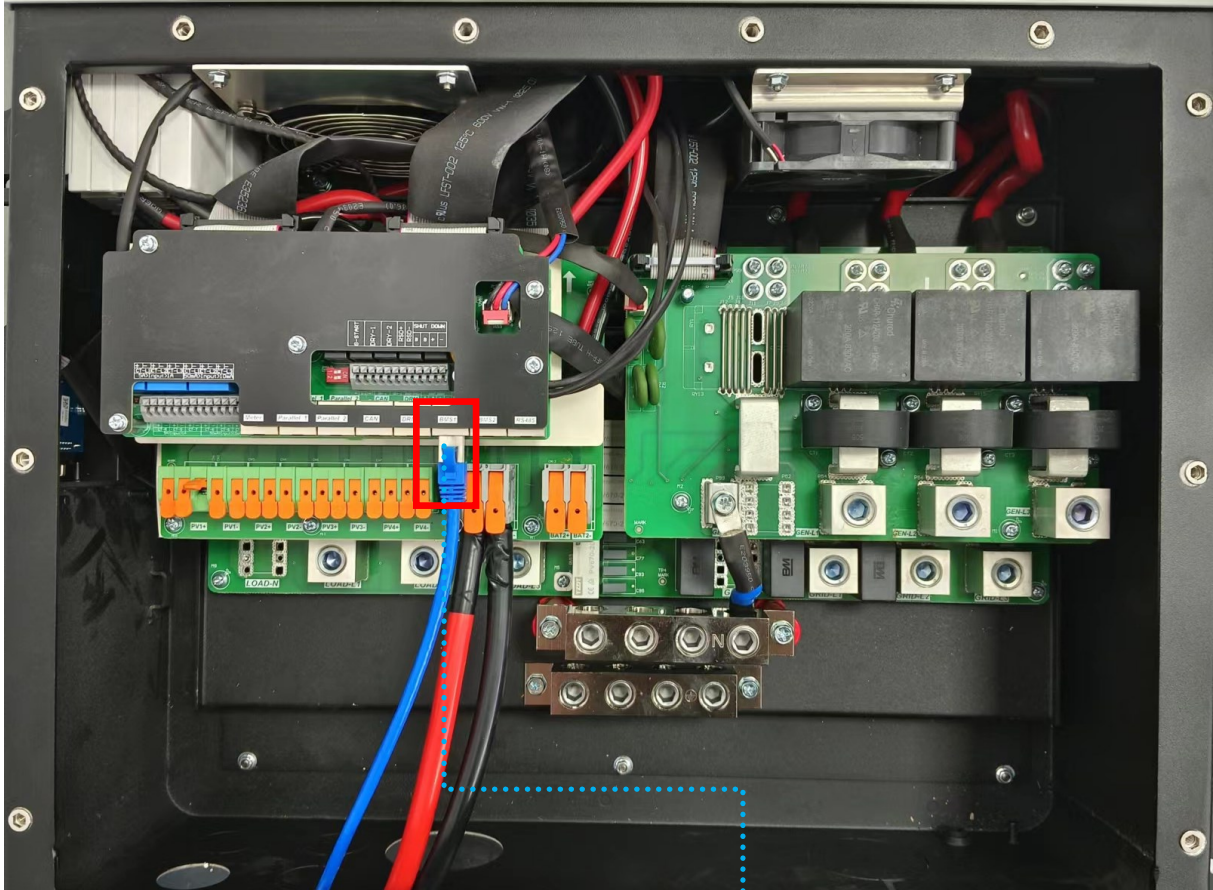

Pic 1.1.1



Pic 1.1.2 HV48100 SE COM1 port (outside of cabinet)

Step 2: Connect the communication cable from "CAN" port of BCU to "Port 0" on BAU as shown in pic 1.1.3 and pic 1.1.4

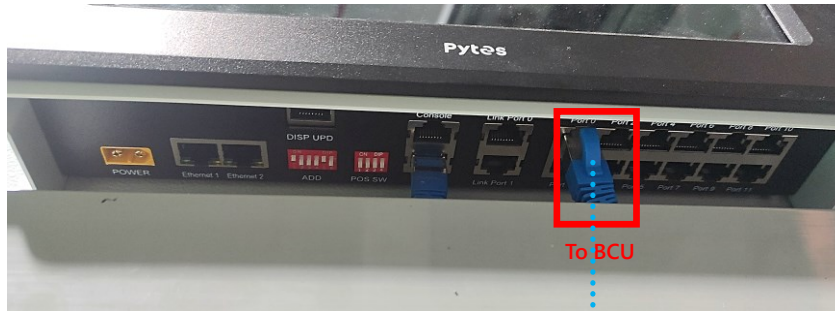

Pic 1.1.3 Port 0 on BAU to BCU



Pic 1.1.4 CAN port on BCU

Step 3: Connect the communication cable from "CAN" port of BAU to COM 1 on the bottom of cabinet. as shown in pic 1.1.5 and pic 1.1.6

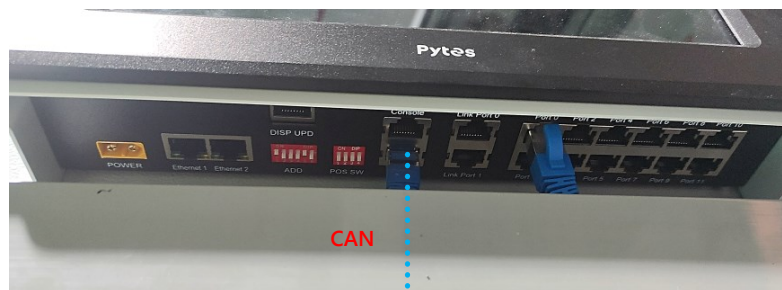

Pic 1.1.5 CAN port on BAU



Pic 1.1.6 HV48100 SE cabinet COM 1 port

2. Power Cable Connection

Step.1

Insert the red cable into the positive DC connector, and insert black cable into negative DC connector as shown in Pic 1.2.1.

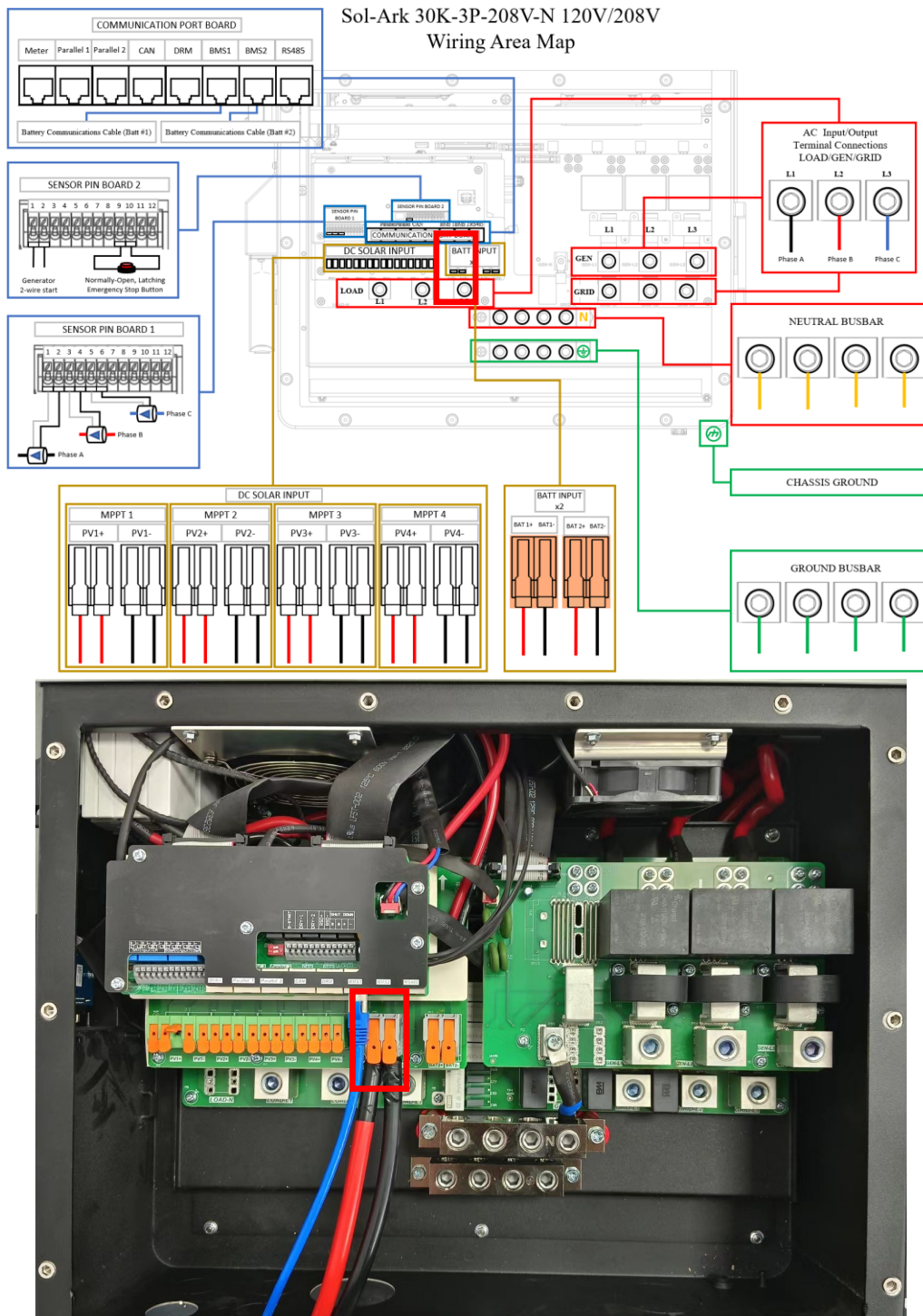

Pic 1.2.1

Step.2

At the other end of the cable, connect to the battery as shown Pic

1.2.2. (Ensure that the battery power switch is off)

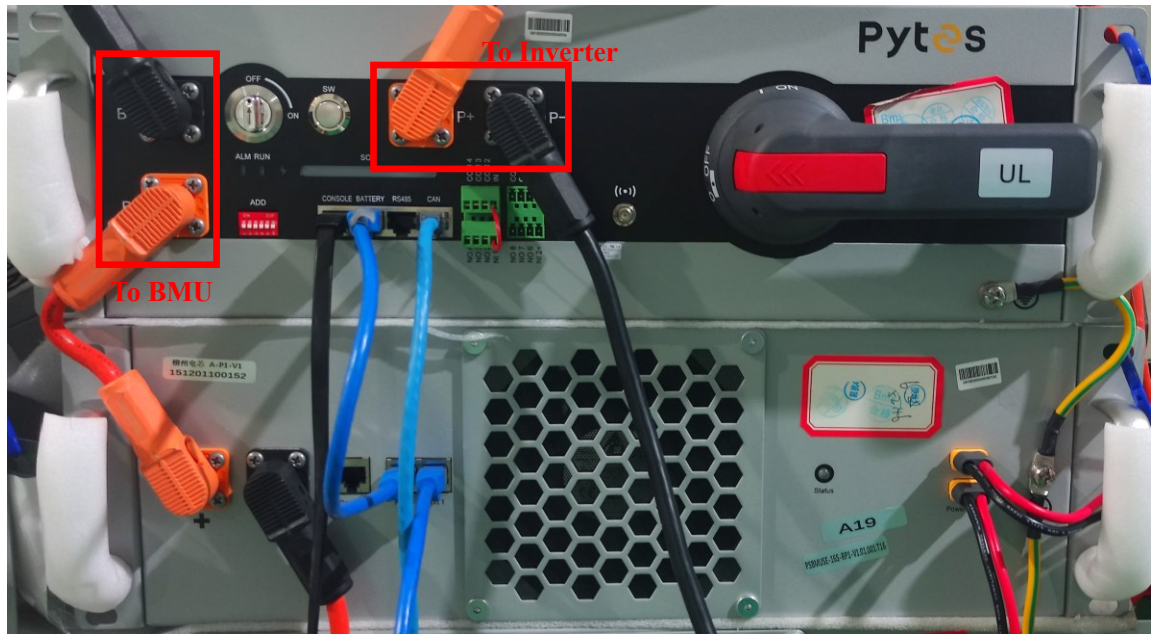

Pic 1.2.2

3. Set The DIP Switch

Before setting the DIP switch, make sure the isolation switch is in the off state.

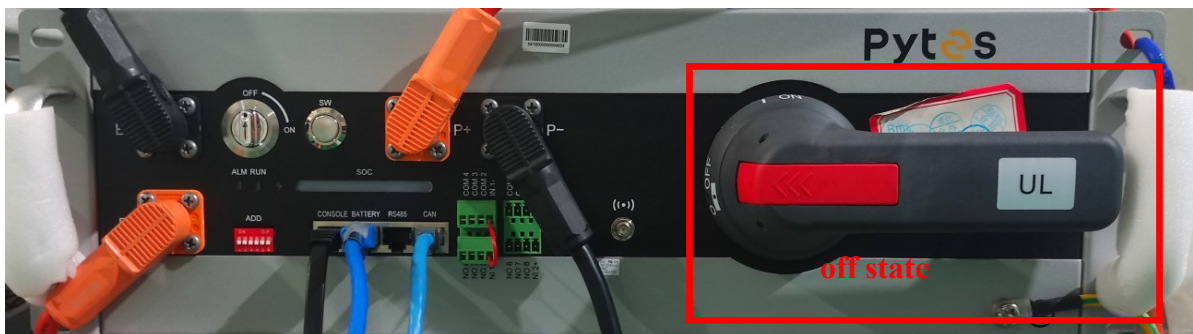

Pic 1.3.1

Then set the DIP switch of BAU as shown in Pic 1.3.2.

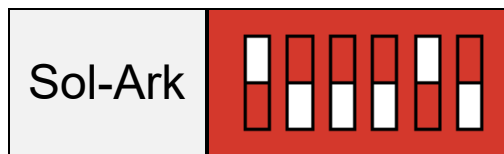

up,down,down,down,up,down

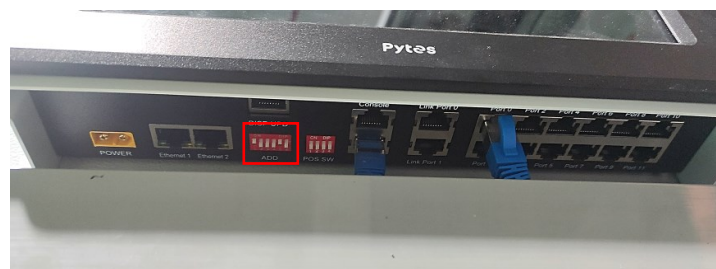

Pic 1.3.2

4.Start up the system

Before Turning on the inverters and batteries, make sure the wires are connected correctly.

Step.1

Turn on the isolation switch.

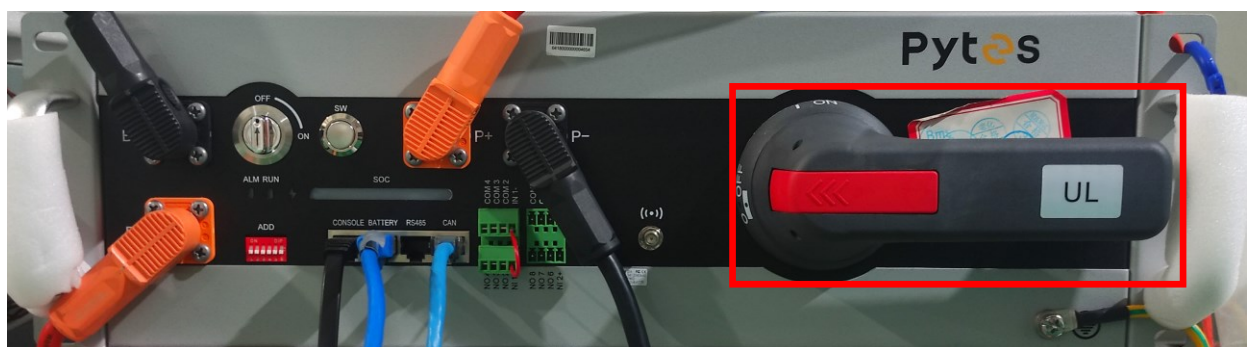

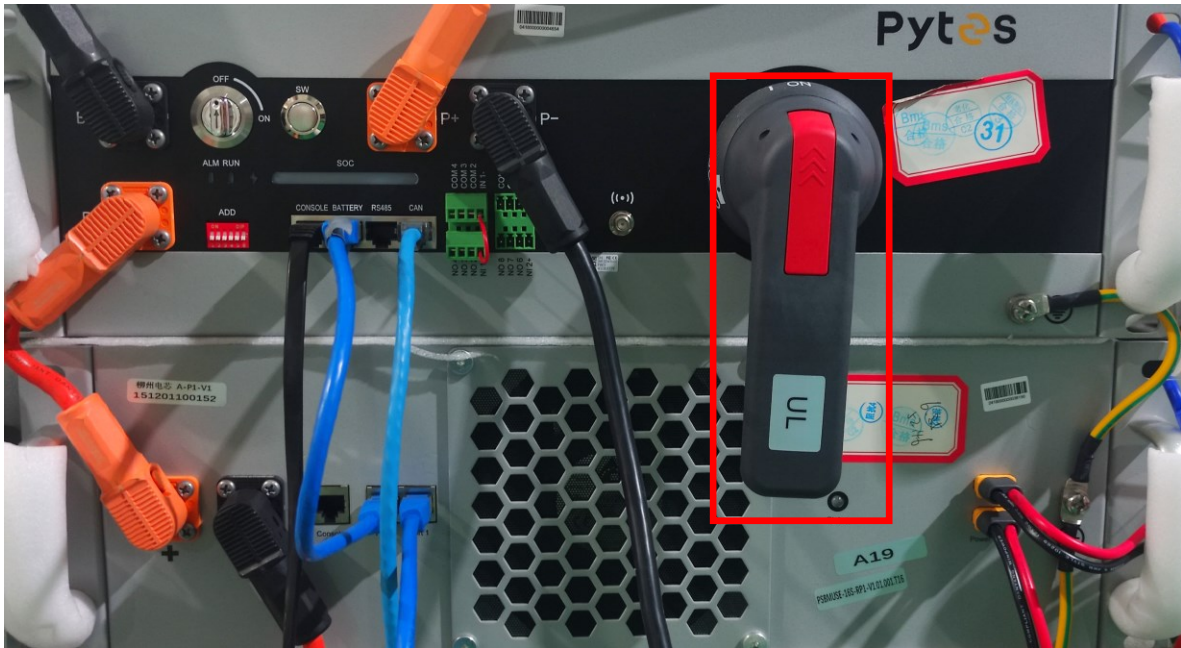

Pic 1.4.1

Step.2

Turn on the power switch.

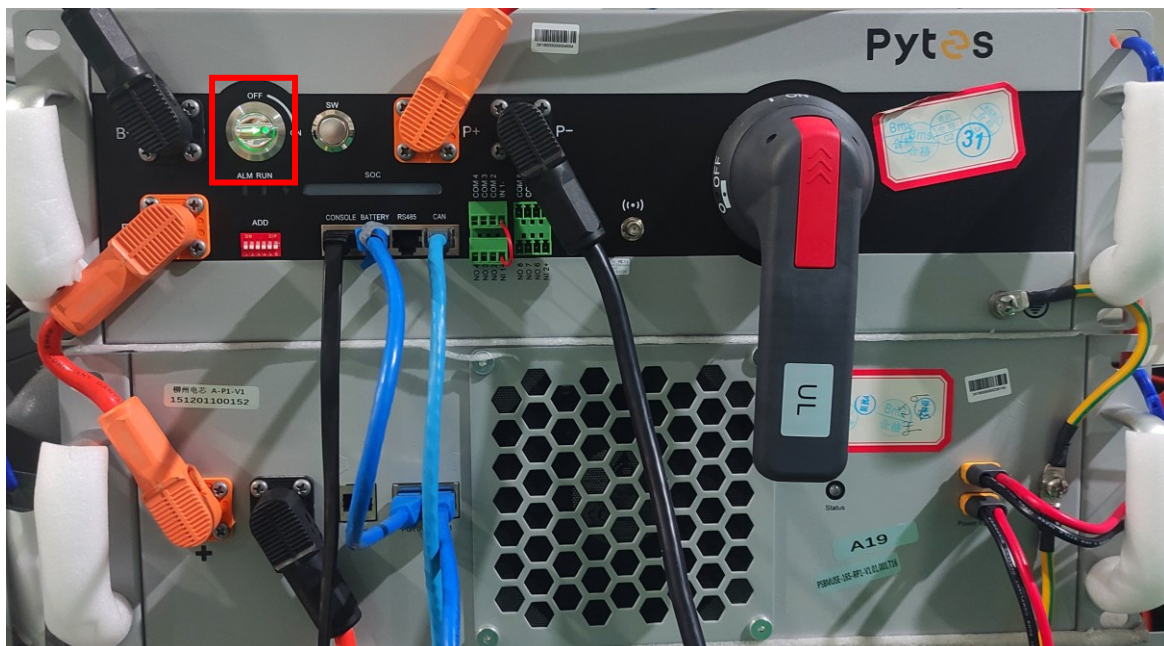

Pic 1.4.2

Step.3 Short press the **SW** button, the RUN light on main control will flicker.

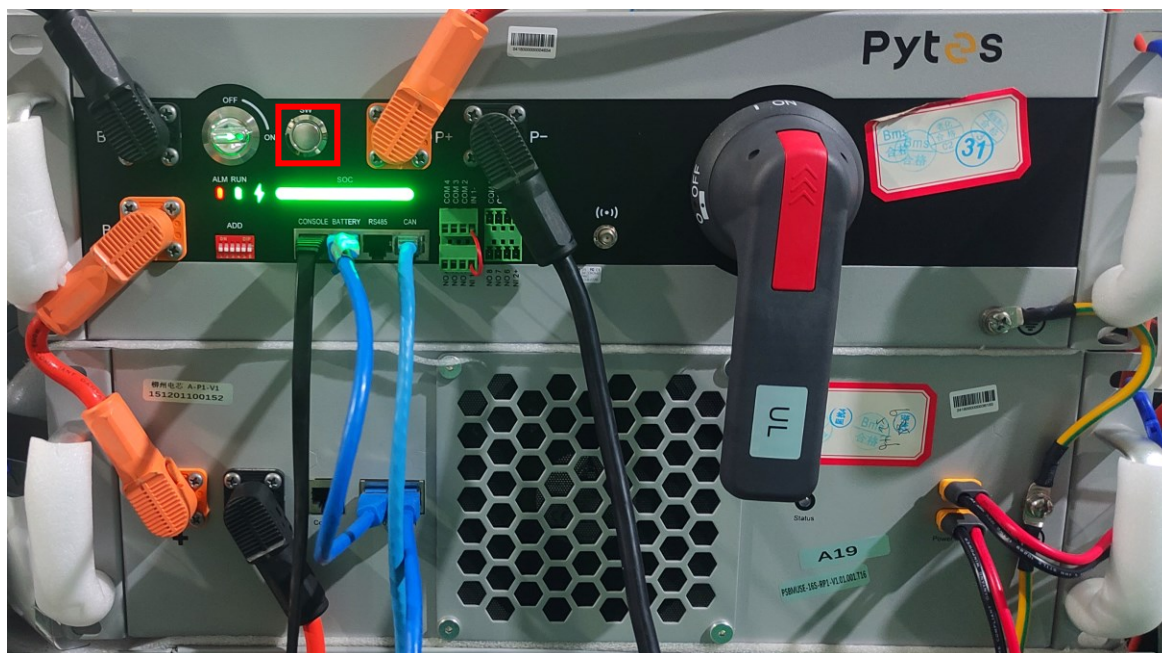

Step.4 Press the inverter button to start the inverter.

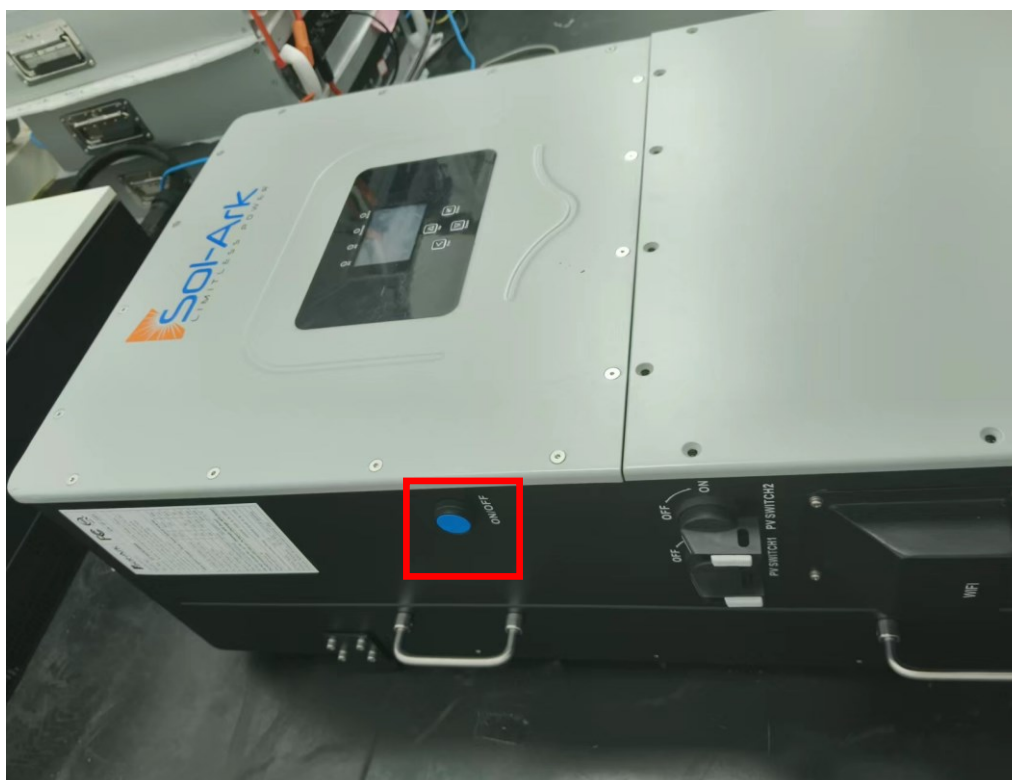

Note: When shut down the system, first press the inverter button to turn off the inverter, and then turn off the battery (first press 3S the red button,

then turn off the power switch), and finally turn off the isolation switch.

5. Change the battery setting of the inverter

※CAUTION: If you want more details about the batteries settings, please check the operating manual of inverters.

Step1.

Change the battery type to **Lithium** in the Battery setting. Use CAN communication, set the **Lithium mode** to 00.

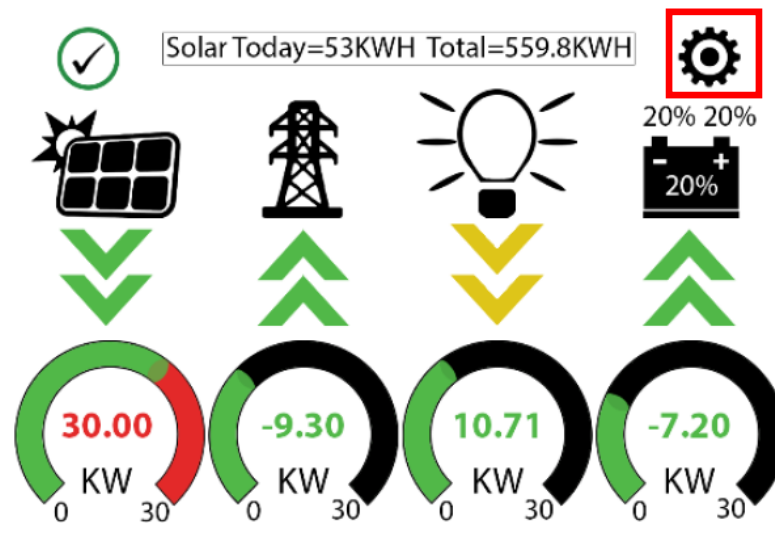

Pic 5.1.1

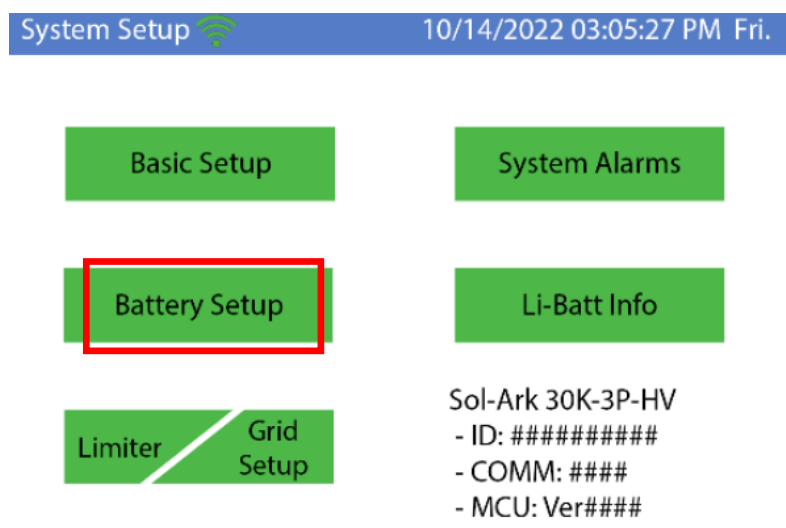

Pic 5.1.2

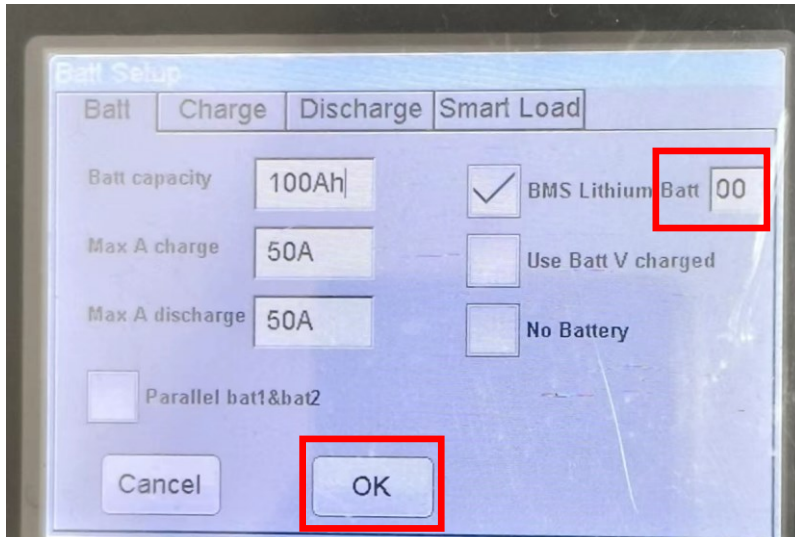

Pic 5.1.3

Step2.

Charge and discharge parameters can be set .



6.Check the battery soc

Step.1

Touch the **Li-Batt Info** of the inverter panel.

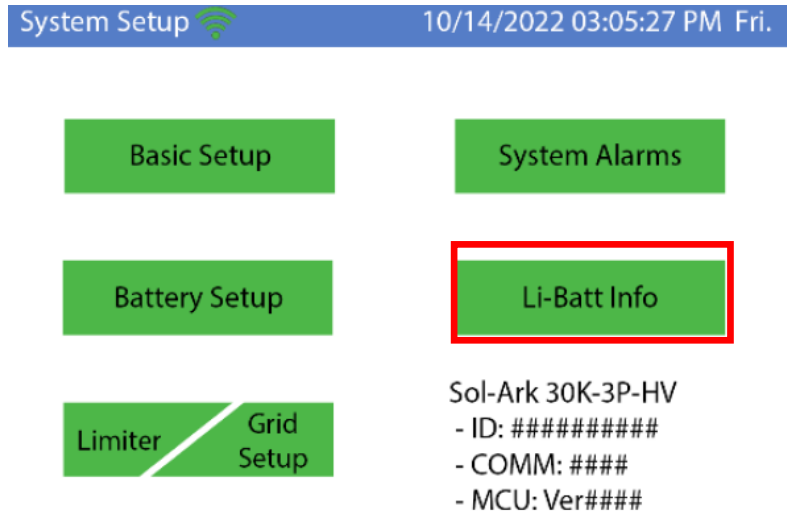

Pic 6.1.1

Step.2

Check the **Li-BMS** in battery information .

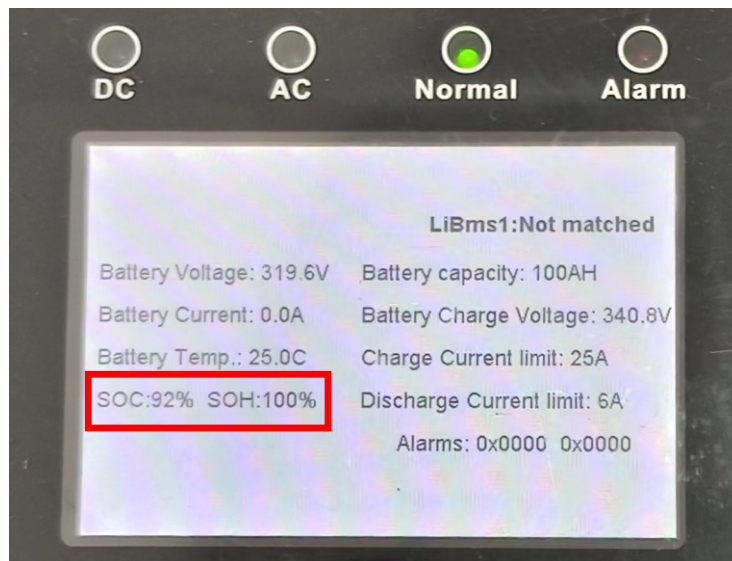

Pic 6.1.2

7.System monitoring

※CAUTION:If you want more details about system monitoring, please check the operating manual of inverters.

Download the app from the app store.



iPhone: (Will only show up as PV Pro)



Android

Register a new account and create a new plant.

-END-